

# Service Schematics

# NOKIA 6111

RM-82

## Introduction

### IMPORTANT:

This document is intended for use by authorized NOKIA service centers only.

“Service Schematics” was created with focus on customer care. The purpose of this document is to provide further technical repair information for NOKIA mobile phones on Level 3/4 service activities. It contains additional information such as e.g. “Component finder”, “Frequency band table” or “Antenna switch table”. The “Signal overview” page gives a good and fast overview about the most important signals and voltages on board. Saving process time and improving the repair quality is the aim of this document. It is to be used additionally to the service manual and other training or service information such as Service Bulletins.

All measurements were made using following equipment:

Nokia repair SW	: Phoenix version 2005.20.7.98
Oscilloscope	: Fluke PM 3380A/B
Spectrum Analyzer	: Advantest R3162 with an analog probe
RF-Generator / GSM Tester	: Rhode & Schwarz CMU 200
Multimeter	: Fluke 73 Series II

While every endeavour has been made to ensure the accuracy of this document, some errors may exist. If the reader finds any errors, NOKIA should be notified in writing.

Please send E-Mail to: [training.sace@nokia.com](mailto:training.sace@nokia.com)

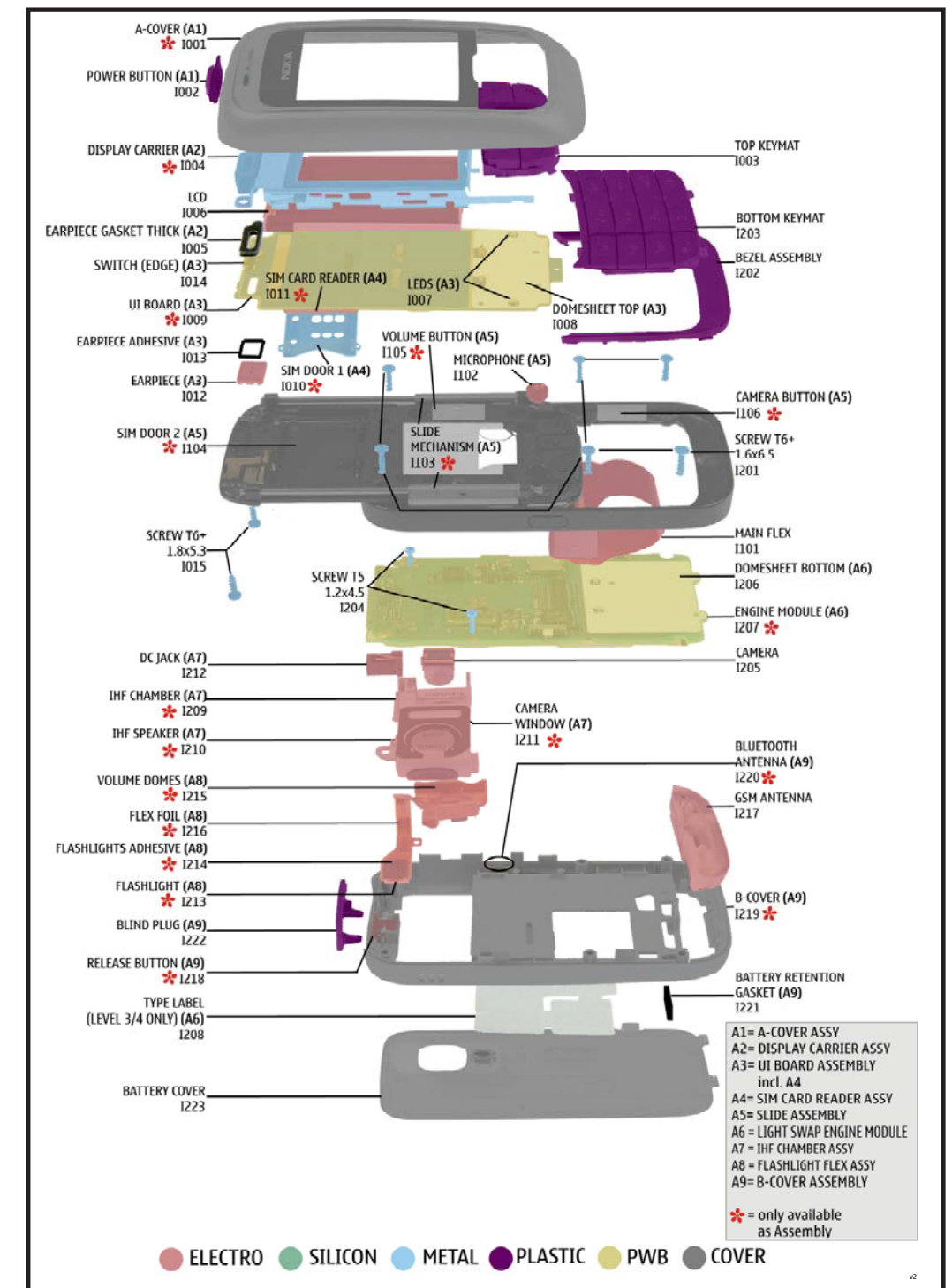
### Copyright © NOKIA

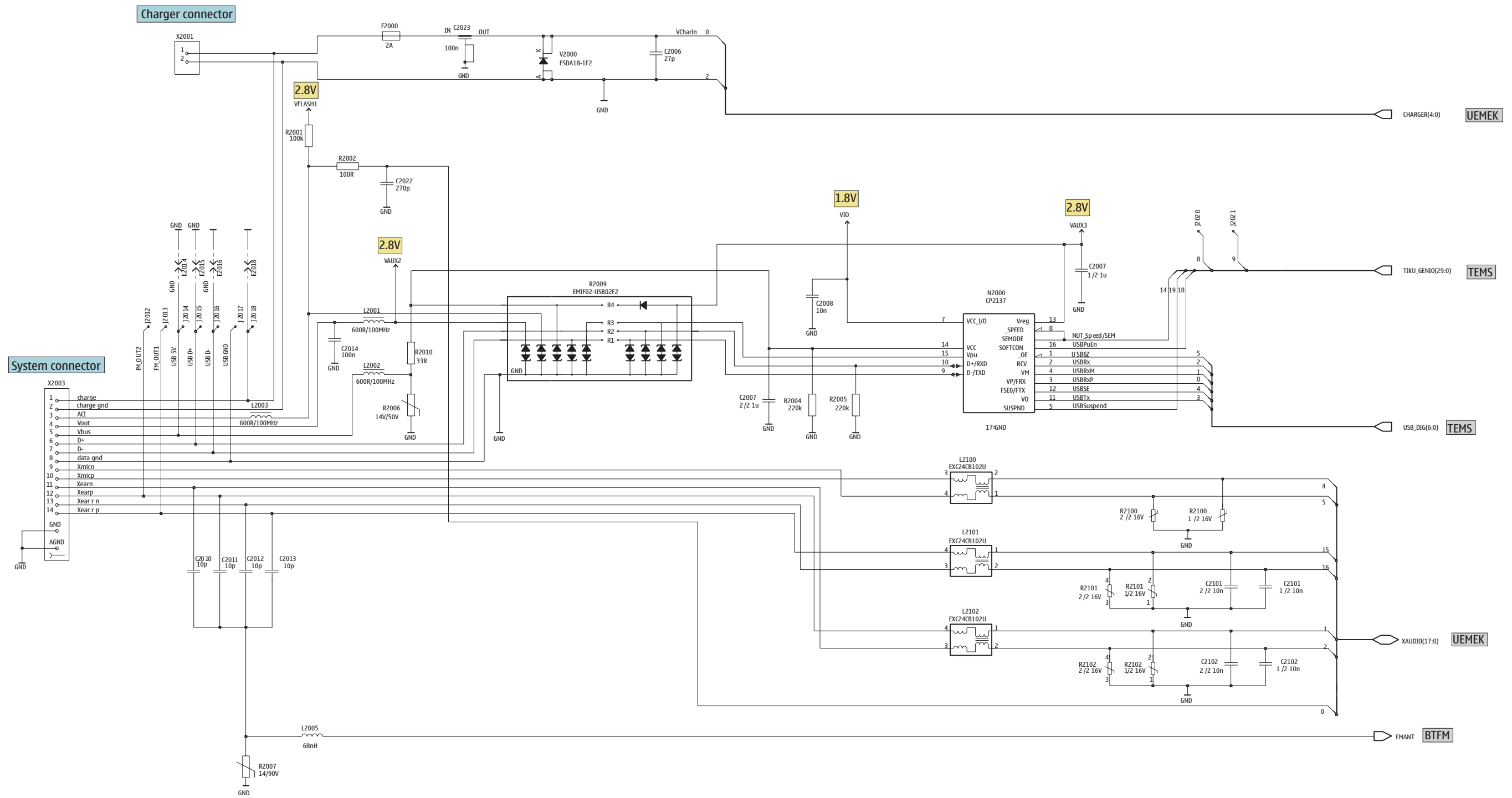
This material, including documentation and any related computer programs is protected by copyright, controlled by NOKIA. All rights are reserved. Copying, including reproducing, modifying, storing, adapting or translating any or all of this material requires the prior written consent of NOKIA. This material also contains company confidential information, which may not be disclosed to others without the prior written consent of NOKIA.

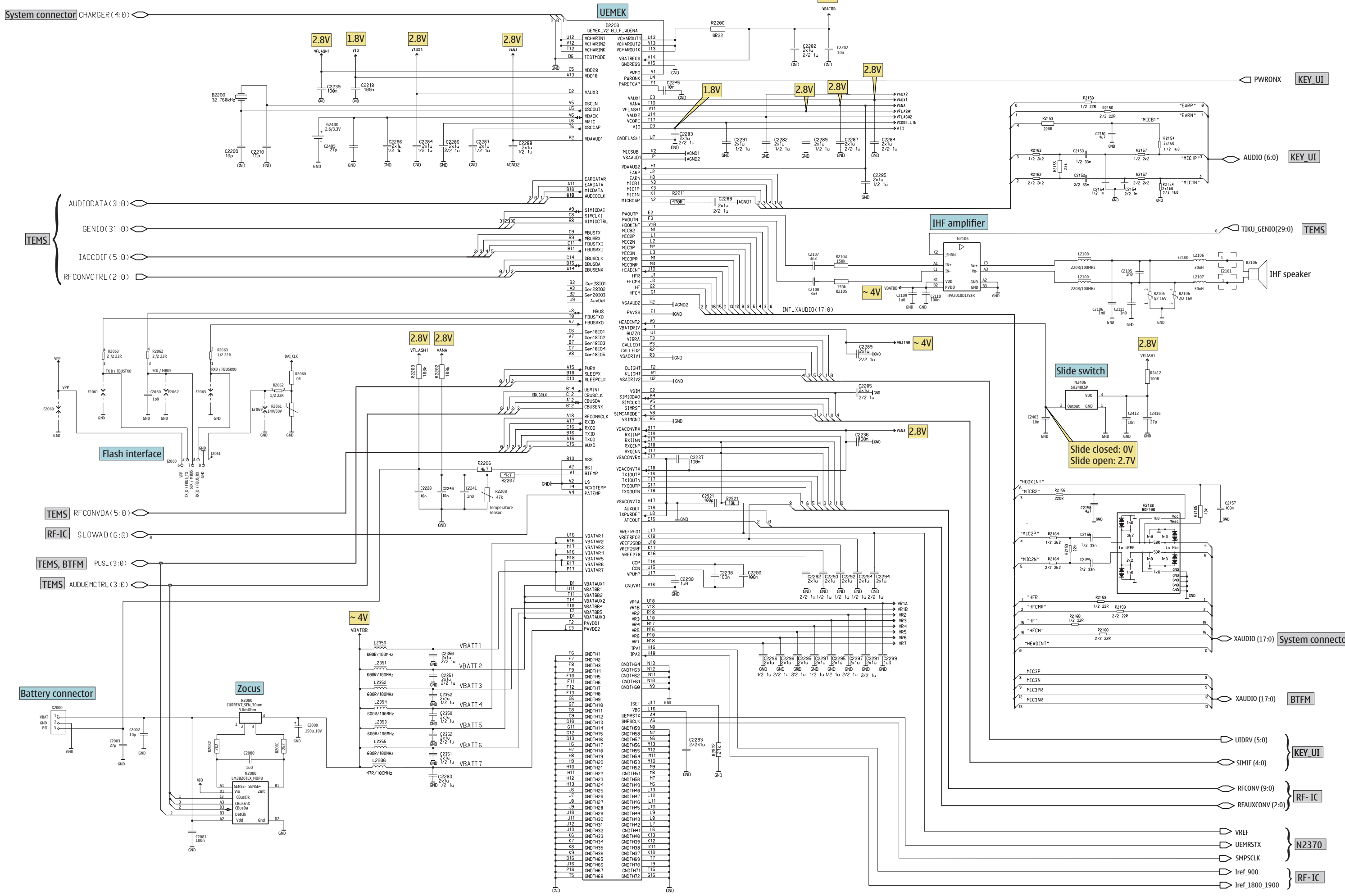


Table of Contents	Page
Front page	1
System connector	2
UEMEK, Audio	3
TEMS, BT, Camera	4
UI	5
UI - Module	6
RF - Part	7
Signal overview	8
Component finder	9

## Exploded view and component disposal

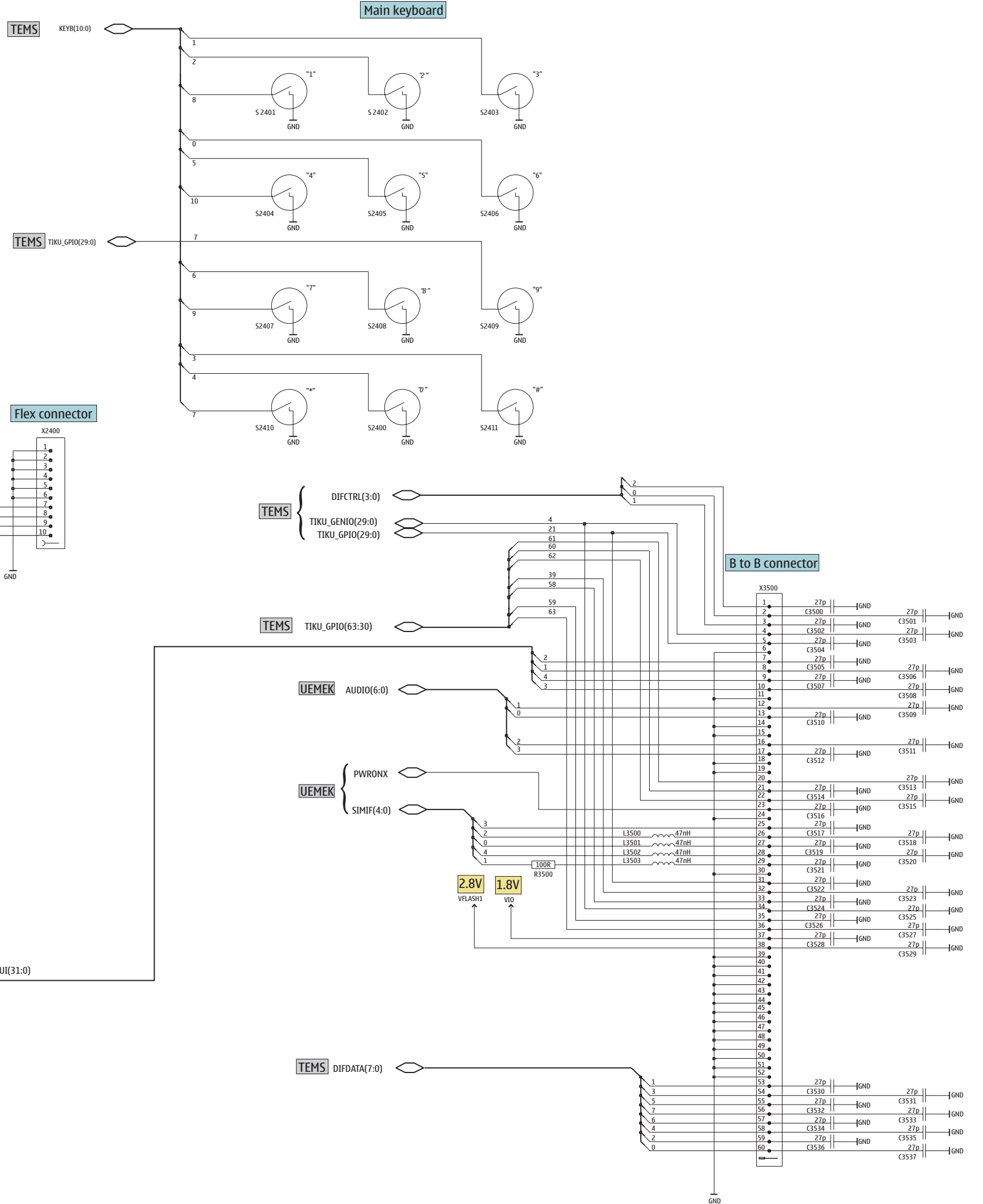
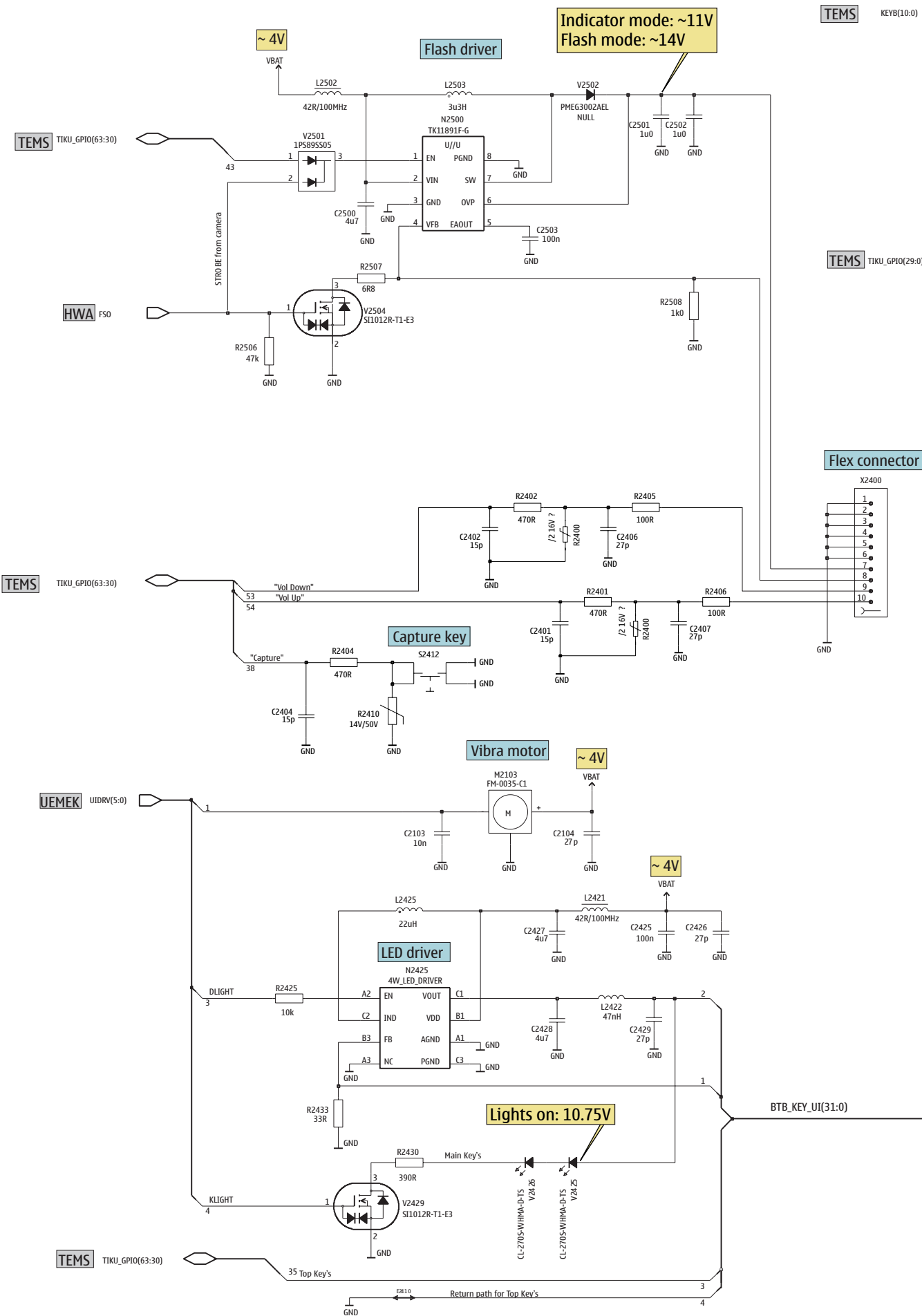


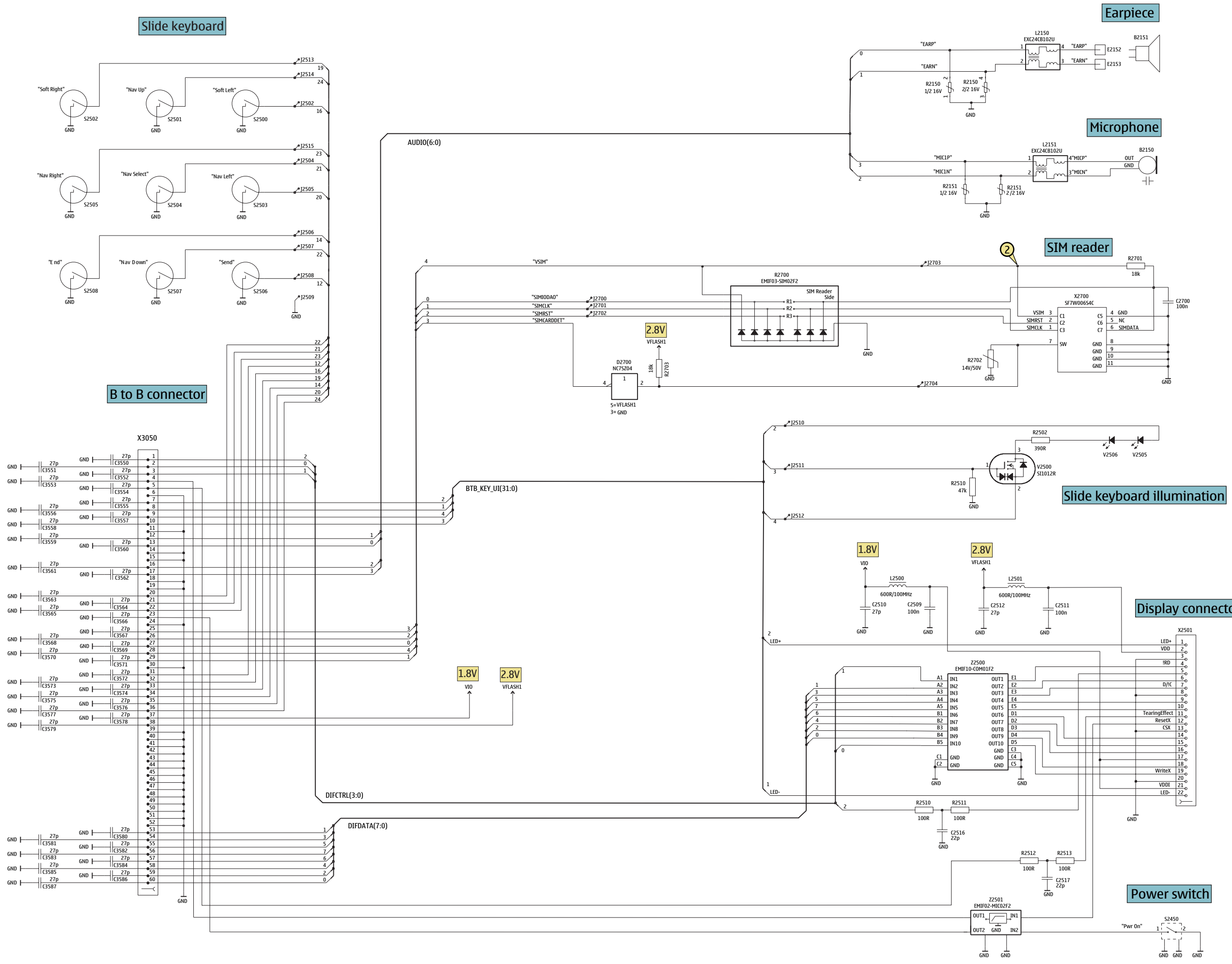


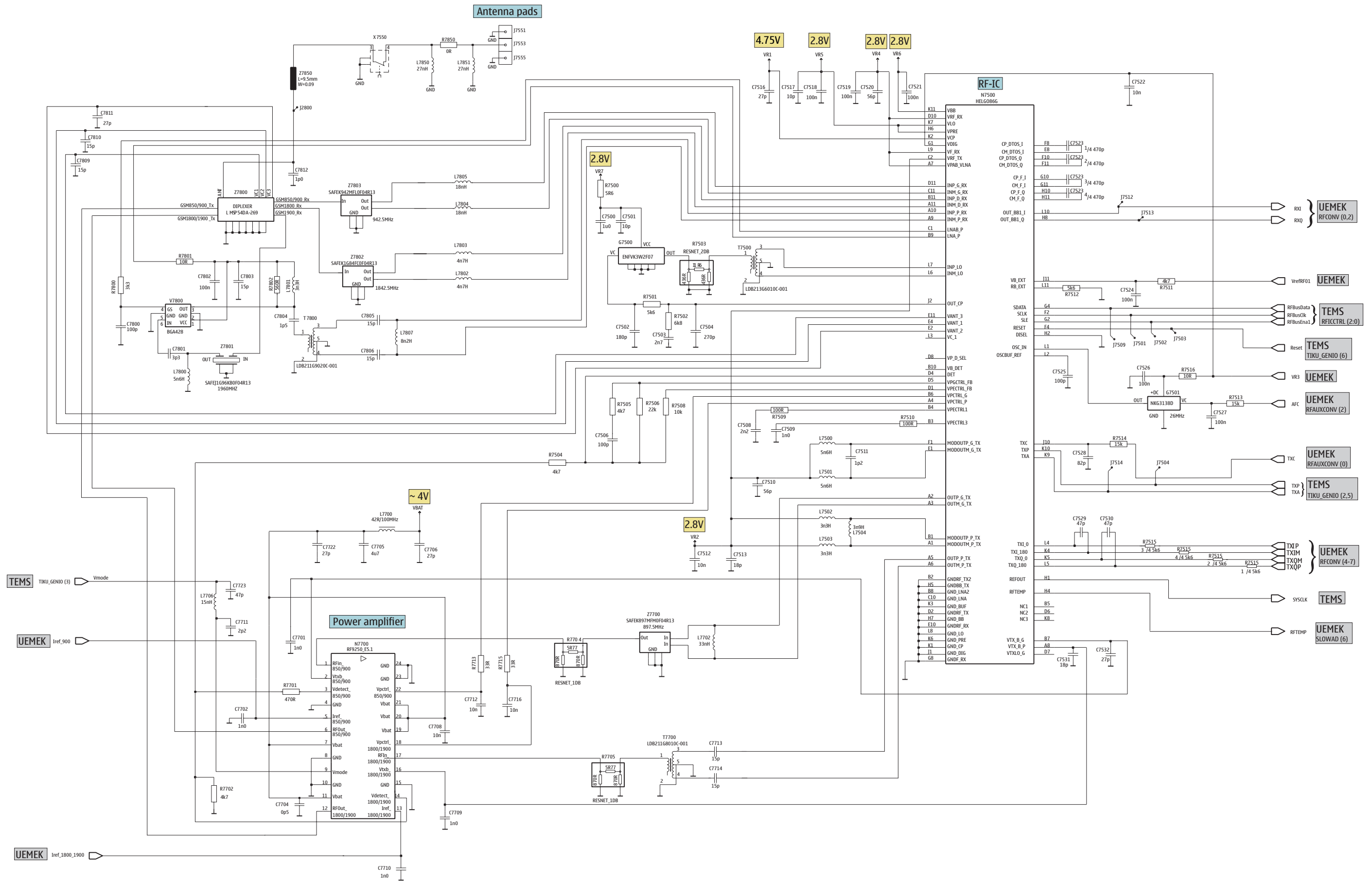




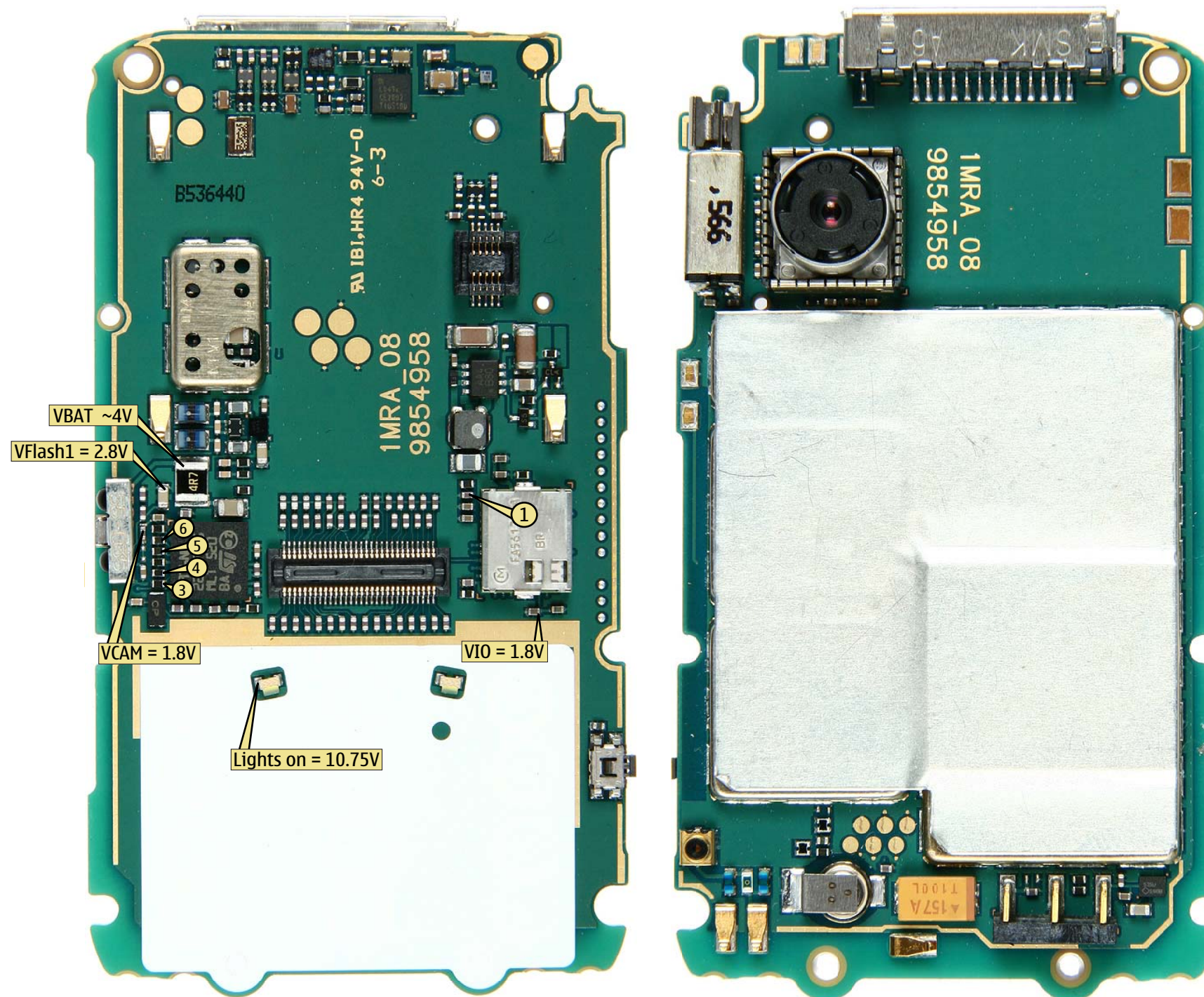
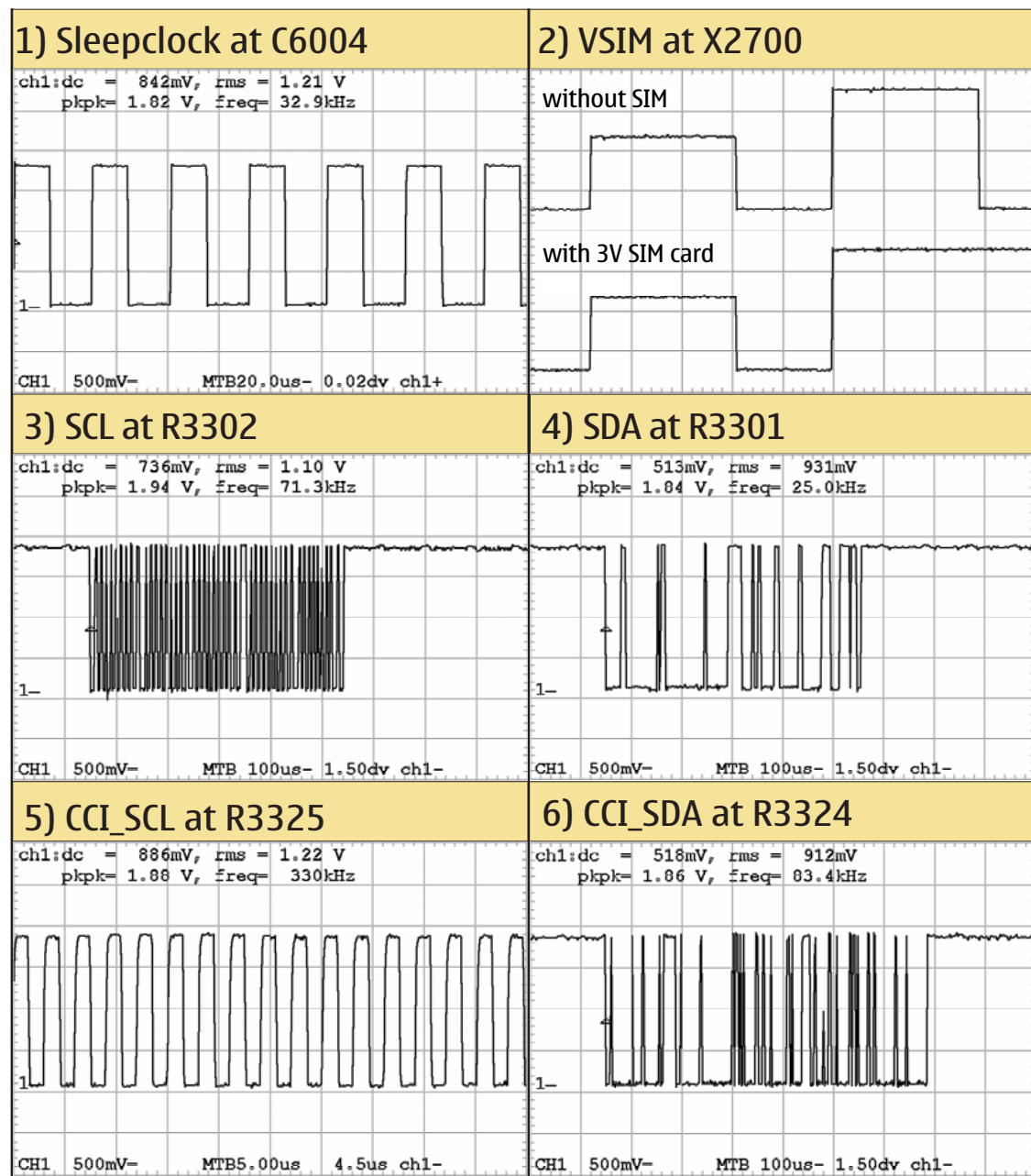














B	C2405	C5	C3519	H6	C7806	H3	J7555	B2	R2080	B8	R7508	H5	
B2200	K8	C2406	M3	C3520	H7	C7809	F3	L	R2081	C8	R7509	H3	
C	C2407	M4	C3521	H7	C7810	F3	L2001	P6	R2082	C8	R7510	G3	
C2000	C6	C2412	G8	C3522	G7	C7811	D3	L2002	O6	R2100	P7	R7511	I3
C2002	C8	C2416	G8	C3523	G7	C7812	D2	L2003	O6	R2101	O7	R7512	I3
C2003	C7	C2425	K8	C3524	G7	D	L2005	O8	R2102	O7	R7513	K2	
C2006	O4	C2426	K8	C3525	G6	D2200	I7	L2100	O7	R2104	I7	R7514	J3
C2007	P5	C2427	K8	C3526	G6	D2800	F7	L2101	O7	R2105	I7	R7515	J4
C2008	O6	C2428	K8	C3527	G6	D3000	F7	L2102	O7	R2106	J8	R7516	K3
C2010	P7	C2429	K7	C3528	G6	D3300	H8	L2106	J8	R2150	I8	R7701	F4
C2011	P7	C2500	J3	C3529	G6	D6000	H3	L2107	J8	R2153	K9	R7702	F4
C2012	P7	C2501	K4	C3530	G6	F	L2108	I8	R2154	K9	R7704	D5	
C2013	P8	C2502	K3	C3531	G5	F2000	P4	L2109	J8	R2155	J9	R7705	F5
C2014	P5	C2503	K4	C3532	G5	G	L2206	H6	R2156	J8	R7713	E5	
C2022	O6	C2600	I8	C3533	G5	G2400	C4	L2350	I6	R2157	K9	R7715	E5
C2023	O4	C2601	H9	C3534	G5	G7500	K4	L2351	H9	R2158	J8	R7800	G2
C2080	B9	C2602	I9	C3535	G5	G7501	K3	L2352	K6	R2159	I8	R7801	F4
C2081	C8	C2603	H9	C3536	G4	J	L2353	K6	R2160	I9	R7802	F4	
C2101	O8	C2801	G6	C3537	G4	J2012	N8	L2354	H6	R2162	J9	R7850	C3
C2102	O7	C2802	E9	C6000	I3	J2013	O8	L2355	I9	R2164	J9	S	
C2103	L2	C2803	F9	C6001	I3	J2014	K6	L2370	D6	R2165	K8	S2400	B6
C2104	L2	C2804	G9	C6002	G3	J2015	K6	L2371	D8	R2166	K9	S2401	F8
C2105	J8	C2805	G9	C6003	G3	J2016	K6	L2421	L8	R2200	K6	S2402	F6
C2106	J8	C2806	E9	C6004	I4	J2017	K6	L2422	K8	R2202	H9	S2403	F3
C2107	I8	C2807	F9	C6184	I4	J2018	P3	L2425	L8	R2203	H8	S2404	D8
C2108	I8	C2808	F9	C6185	H4	J2020	F6	L2502	I4	R2206	H8	S2405	D6
C2109	I7	C2809	G6	C7500	K4	J2021	F6	L2503	J4	R2207	H8	S2406	D3
C2110	J7	C2810	E9	C7501	K5	J2060	C5	L3320	M3	R2208	H9	S2407	C8
C2111	J8	C2811	E9	C7502	J5	J2061	C4	L3321	L4	R2211	I9	S2408	C6
C2151	K9	C2812	F6	C7503	J5	J2400	J3	L3322	H9	R2400	M4	S2409	C3
C2153	J9	C2813	F6	C7504	J4	J2401	J9	L3500	I6	R2401	M4	S2410	B8
C2154	J9	C2814	H9	C7506	G5	J2402	N3	L3501	I6	R2402	M4	S2411	B3
C2155	J9	C2815	E6	C7508	G3	J2403	N9	L3502	I7	R2404	G4	S2412	E2
C2157	K8	C2816	F9	C7509	G3	J2800	H7	L3503	I7	R2405	M4	T	
C2158	K8	C2817	E6	C7510	I5	J2801	H7	L7500	I5	R2406	M4	T7500	J3
C2200	J7	C2818	G9	C7511	I4	J2802	H7	L7501	I5	R2410	E2	T7700	G4
C2202	J8	C2819	G6	C7512	I4	J2803	H6	L7502	H5	R2412	G7	T7800	H2
C2209	J8	C2820	E6	C7513	H5	J2804	E9	L7503	H5	R2425	L8	V	
C2210	K7	C2823	H9	C7516	J4	J2807	H7	L7504	H4	R2430	K8	V2000	O4
C2218	H7	C2824	H7	C7517	J3	J2808	H7	L7700	F5	R2433	L7	V2425	F7
C2220	H8	C2825	H6	C7518	J4	J2810	H7	L7702	H4	R2506	J3	V2426	F4
C2236	H6	C2830	D9	C7519	H3	J2811	H7	L7706	E3	R2507	K3	V2429	K8
C2237	J7	C2831	G9	C7520	J3	J2812	H7	L7800	F2	R2508	K3	V2501	J3
C2238	J7	C2921	H6	C7521	I3	J2813	H7	L7801	F4	R2600	I8	V2502	K4
C2239	H8	C2922	F6	C7522	I4	J2814	H7	L7802	H3	R2800	E6	V2504	K3
C2240	H9	C3303	H9	C7523	I2	J2816	E9	L7803	H3	R2802	F9	V7800	F3
C2241	H9	C3304	H7	C7524	I3	J2817	E6	L7804	I3	R2806	G9	X	
C2245	I8	C3305	G8	C7525	J4	J2818	E7	L7805	H3	R2807	E9	X2000	B7
C2282	K7	C3306	H7	C7526	K2	J2820	H8	L7807	H3	R2808	H9	X2003	P6
C2283	H7	C3307	G7	C7527	K3	J2821	E6	L7850	C2	R2809	E9	X2005	N7
C2284	H8	C3308	H8	C7528	J3	J2822	H7	L7851	C3	R2810	E6	X2400	L4
C2285	I9	C3309	G8	C7529	J4	J2834	H7	M	R2820	G9	X3180	D7	
C2286	K7	C3320	L3	C7530	J4	J2835	H8	M2103	M2	R2821	G9	X3320	M4
C2287	K8	C3321	M3	C7531	H3	J2836	E9	N	R2830	D9	X3500	H6	
C2288	J9	C3322	M3	C7532	H3	J2837	H6	N2000	O5	R2831	G9	X7550	C2
C2289	K7	C3323	N3	C7701	D4	J6000	G2	N2080	C9	R2850	G6	Z	
C2290	K7	C3324	L4	C7702	D4	J6001	H2	N2106	J7	R2851	I8	Z7700	G4
C2291	J6	C3325	L4	C7704	E3	J6002	J2	N2370	C6	R2852	F6	Z7800	E3
C2292	H6	C3326	I9	C7705	F3	J6003	I2	N2371	C7	R2853	F6	Z7801	F2
C2293	H6	C3500	I4	C7706	G4	J6004	J2	N2406	G9	R2920	F6	Z7802	H2
C2294	I6	C3501	H5	C7708	E5	J6005	I2	N2425	L8	R2921	H6	Z7803	I2
C2295	I6	C3502	I5	C7709	F4	J6006	I2	N2500	K4	R2922	I6	Z7850	D2
C2296	J6	C3503	H5	C7710	F4	J6007	I2	N2600	H9	R3301	H9	Z7851	D3
C2297	J6	C3504	I5	C7711	E3	J6008	H2	N7500	I4	R3302	G9		
C2299	K6	C3505	H5	C7712	E5	J6009	G2	N7700	E4	R3320	H9		
C2350	I6	C3506	I5	C7713	H4	J6010	H2	R	R3321	H9			
C2351	H8	C3507	H5	C7714	H4	J6015	G2	R2001	O6	R3324	H9		
C2352	J6	C3508	I5	C7716	F5	J6020	J2	R2002	O6	R3325	H9		
C2370	D6	C3509	I5	C7719	D3	J7501	I5	R2004	P5	R3500	I7		
C2371	D7	C3510	H5	C7720	F4	J7502	I5	R2005	O6	R6001	I3		
C2372	D6	C3511	H6	C7722	F5	J7503	I5	R2006	O6	R6002	I4		
C2373	D7	C3512	I6	C7723	D3	J7504	J2	R2007	P8	R7500	K5		
C2374	D8	C3513	H6	C7800	G3	J7509	I5	R2009	P6	R7501	J5		
C2375	D8	C3514	H6	C7801	F3	J7512	J3	R2010	O6	R7502	I4		
C2401	N4	C3515	I6	C7802	F4	J7513	J3	R2060	C4	R7503	K4		
C2402	N4	C3516	H6	C7803	F3	J7514	J2	R2061	C4	R7504	G5		
C2403	G9	C3517	I6	C7804	G4	J7551	B5	R2062	D4	R7505	G5		
C2404	G4	C3518	H6	C7805	H3	J7553	B3	R2063	C3	R7506	H5		

